

**The CURVE allows any user, regardless of size or weight, to instantly achieve the speed they desire without the use of elevation or a motor!**

The CURVE's sophisticated design is the culmination of years of non-motorized design and development by WOODWAY. The key ingredient is WOODWAY's patented running surface and near-frictionless drive system, which allows the running belt to move freely.

**Totally Green Treadmill - HUMAN POWER!**

The user controls their speed by positioning their body along the curved running surface. Stepping forward initiates movement, as the user propels themselves up the curve the speed increases. To slow, simply drift back towards the rear curve.



**Dimensions**

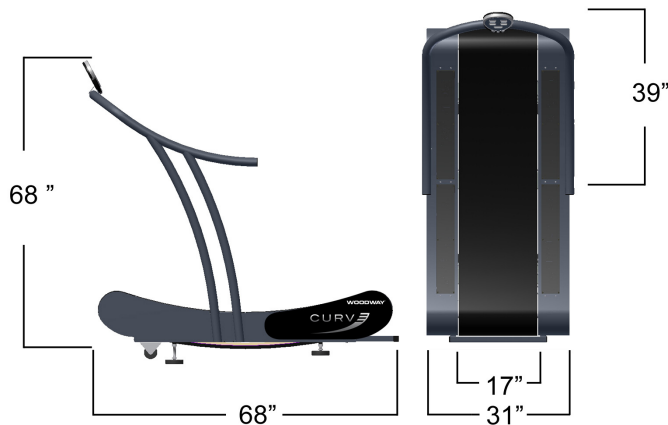

**Ultimate Sports Performance Training Platform**

- Users are not subject to ramp up/down speeds
- Attain full sprint in a few explosive steps
- Sports specific work to rest interval training
- No maximum speed

**LED Window Display**

**Physical Specifications**

Belt Type	60 individual slats
Drive System	114 precision ball bearings with 12 roller guides (4 mm lateral tolerance)
Running Surface	Vulcanized rubber (38-43 shore hardness)
Drive Motor	Human Power
Unit Weight	245 lb.
Power Supply	Does not require power

**Performance Specifications**

User Weight Capacity	Running 500 lb. Walking 800 lb.
Running Surface Area	17" X 64"
Speed Range	no maximum speed
Elevation Range	Innovative curved design
Standard Fitness Warranty	5 year wear warranty 5 year all components 2 year on battery operated display 1 year labor



There are 5 seven-segment displays that show program statistics (TIME, CALORIES, DISTANCE & PULSE (HEART RATE)). The four-digit displays are programmed to display time in an 88:88 format.

There are three functional buttons that are used to set, toggle and display data.