

The WOODWAY Force is the ultimate training tool developing human performance

### Speed and Power Training Platform

- Variable load braking system
- Easy to use tether
- Accurate performance testing and measurement
- Polar monitor circuitry – integrated heart rate monitoring
- Advanced SlatFlex® shock absorption

### Convenient User Console

- User friendly side handrail control of load, timing clock and stop
- Multiple LED readouts monitoring speed, load, distance, time, and heart rate
- 6 Custom user programs
- CSAFE fitness communications compatible
- Preprogrammed controls including speed over distance, distance over time, etc.



\* Force 2.0 model shown above

### Dimensions

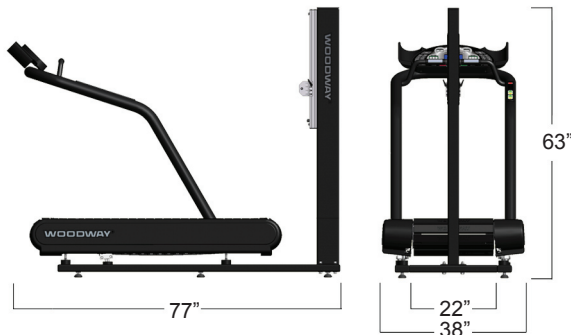

### Upgrade to Force 2.0 or Force 3.0 models for improved programability and functionality

#### Force 2.0

- 1 horizontal load cell attached to the vertical strut
- Desktop computer and software includes: multiple readout displaying time, velocity, work, power, and distance
- Ability to save and compare data to previous activity or participants
- Ability to graph each parameter against time
- Pacer function

#### Force 2.5

- 4 individual vertical load cells under the running surface
- 1 horizontal load cell attached to the vertical strut
- Treadmill tachometer function
- Desktop computer and software includes: multiple readout displaying time, velocity, work, power and distance
- Ability to save and compare data to previous activity or participants
- Ability to graph each parameter against time
- Gait analysis for sport specific research for University level human performance research and professional sports teams
- Pacer function

### Physical Specifications

Belt Type	60 individual slats
Drive System	114 precision ball bearings with 12 guide rollers (4 mm lateral tolerance)
Running Surface	Vulcanized rubber (38-43 shore hardness)
Load/Resistance System	Electromagnetic braking system provides 15-150 lb. of resistance
Unit Weight	560 lb. (shipping weight 639 lb.)
Power Supply	110 V power supply (dedicated circuit and NEMA 5-20R outlet receptacle required)

### Performance Specifications

User Weight Capacity	800 lb.
Running Surface Area	22" X 68"
Performance Indicators	Speed, Load and Distance
Standard Fitness Warranty	5 year drive and belt 3 year all components 1 year labor

### Additional Options:

- Polar monitor chest strap
- 220 V or 208 V – 50/60 Hz power supply (NEMA 6-20R)
- Single handrail
- Upgrade to laptop computer & cart w/ software preloaded
- Additional belts (XS-5XL)

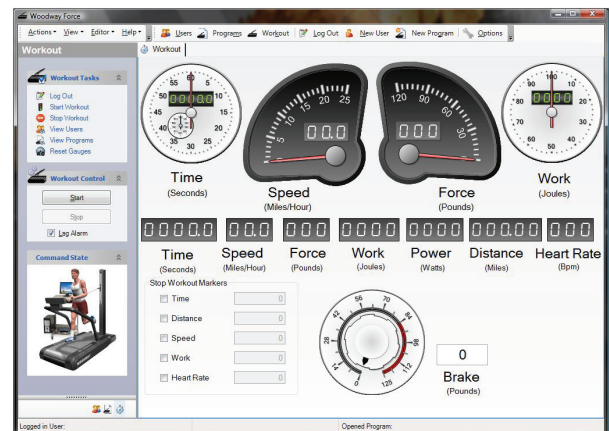

Pictured above: Performance reporting function example produced using Force Software. Software is standard with Force 2.0 and 3.0 and an upgrade option for 1.0 model.